

REV.	DESCRIPTION	BY	DATE
0	INITIAL CONTROL.	cmansfield	11/20/2023

Exicor 800HD:

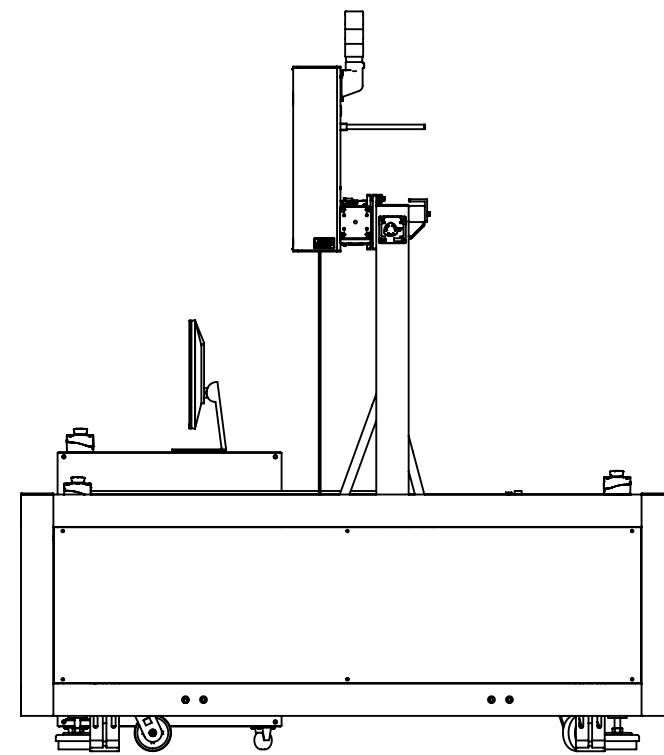
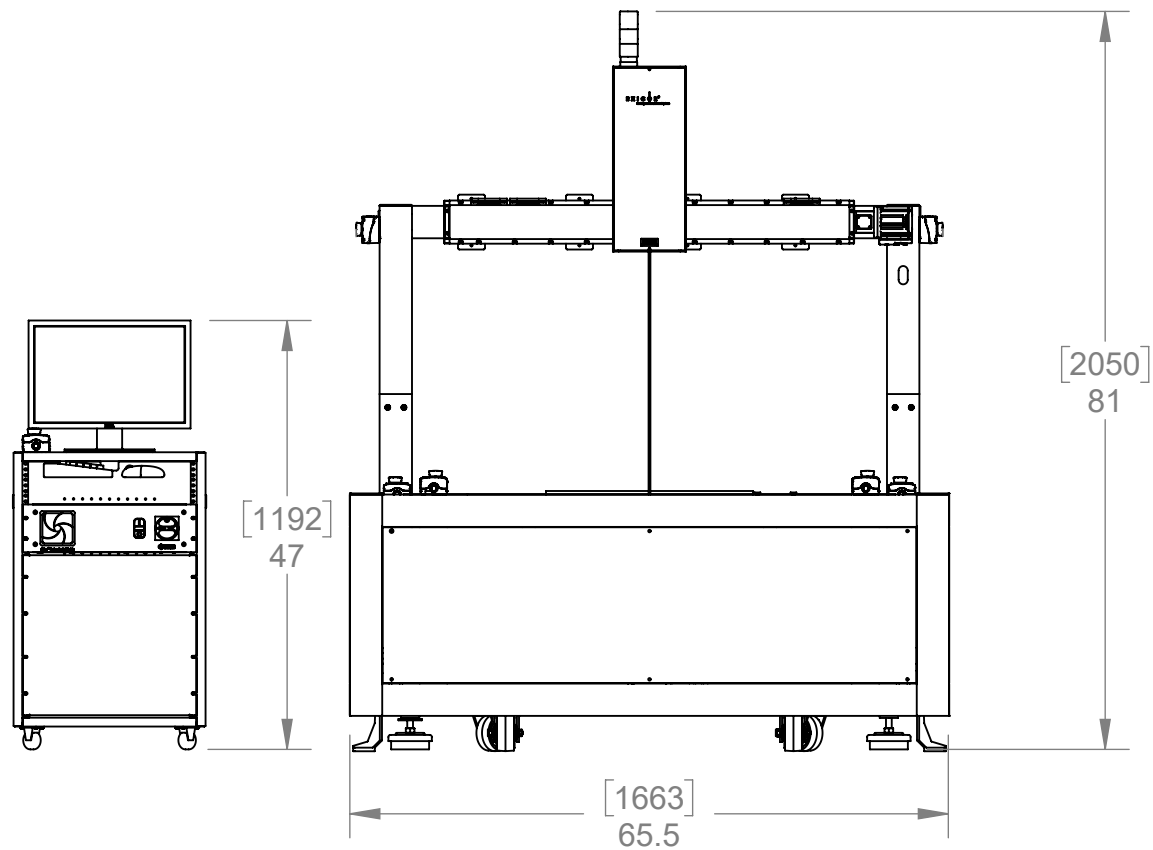
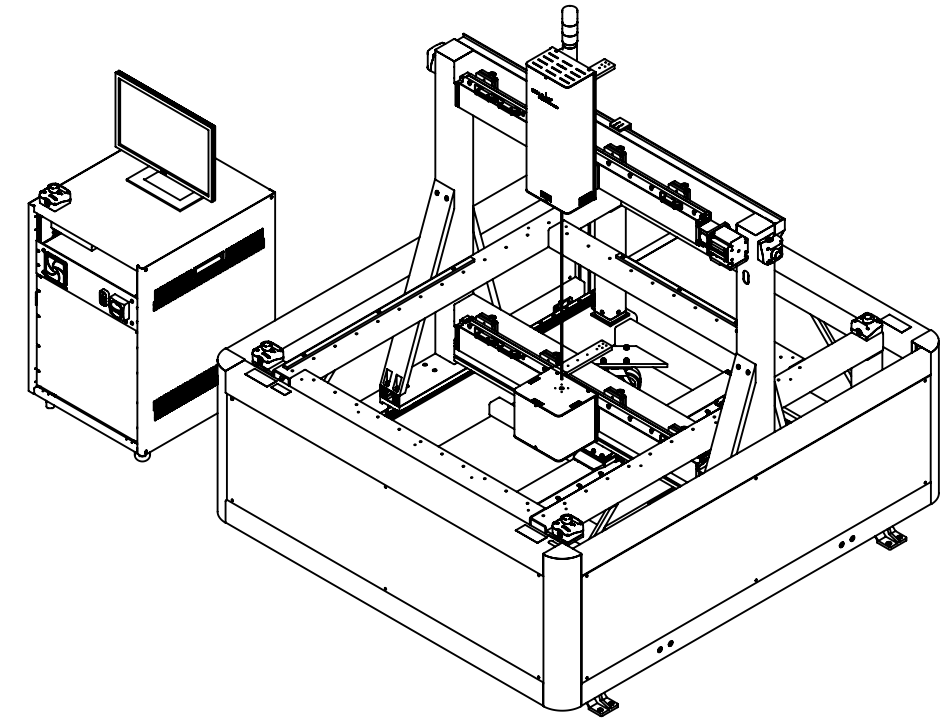
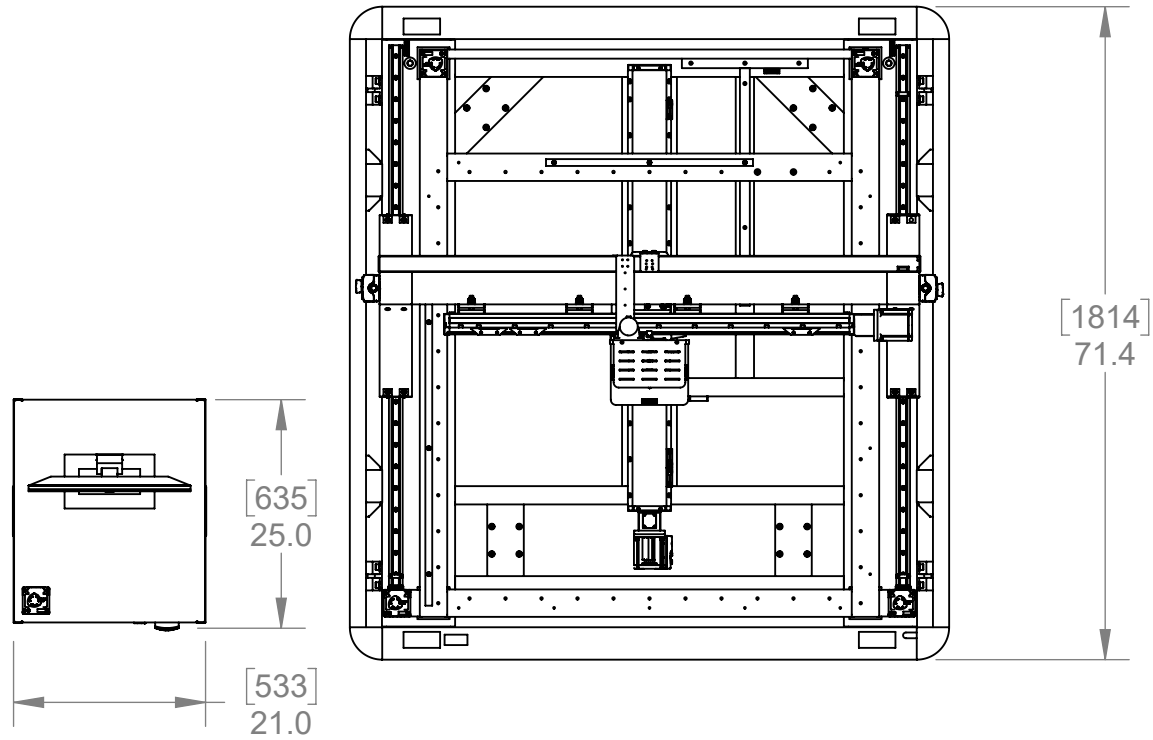

DIMENSIONS: INCH [mm]

UNSPECIFIED LIMITS DIMENSIONS ARE IN INCHES		DO NOT SCALE DRAWING		HINDS Instruments, Inc. <small>7245 NE Evergreen Pkwy, Suite 150 Hillsboro, OR 97124 PHONE (503) 690-2000 FAX (503) 690-3000</small>
FRACTIONS ± 1/32	STRAIGHTNESS &/OR FLATNESS: .005/INCH	DATE PRINTED:		
DECIMALS .XX ± .010 .XXX ± .005 .XX ± .010	THREADS: EXTERNAL - CLASS 2A INTERNAL - CLASS 2B	APPROVALS	DATE	
HOLE DIA's .XXX + .003 - .001	UNMARKED ANGLES, BENDS & INTERSECTIONS: 90°	cmansfield	11/20/23	
ANGLES ± 2°	MACHINED SURFACES: 63 OR BETTER	CHECKED		
BENDS ± 2°	REMOVE ALL BURRS & SHARP CORNERS	MATERIAL		
PERPENDICULARITY .003/INCH		FINISH		
CONCENTRICITY .003 TIR				
SAMPLES MUST BE APPROVED BY ENGINEERING DEPARTMENT PRIOR TO STARTING PRODUCTION		MATERIAL		SIZE B
THIS DRAWING IS THE PROPERTY OF HINDS INSTRUMENTS INC. ALL RIGHTS RESERVED.		FINISH		FSCM NO. 010-0000-113-R
				DWG. NO. 010-0000-113-R
				REV. 0
				SCALE 1:21
				RELEASE DATE:
				SHEET 1 OF 2

Exicor 800HD: Gantry Max Back Loading Position

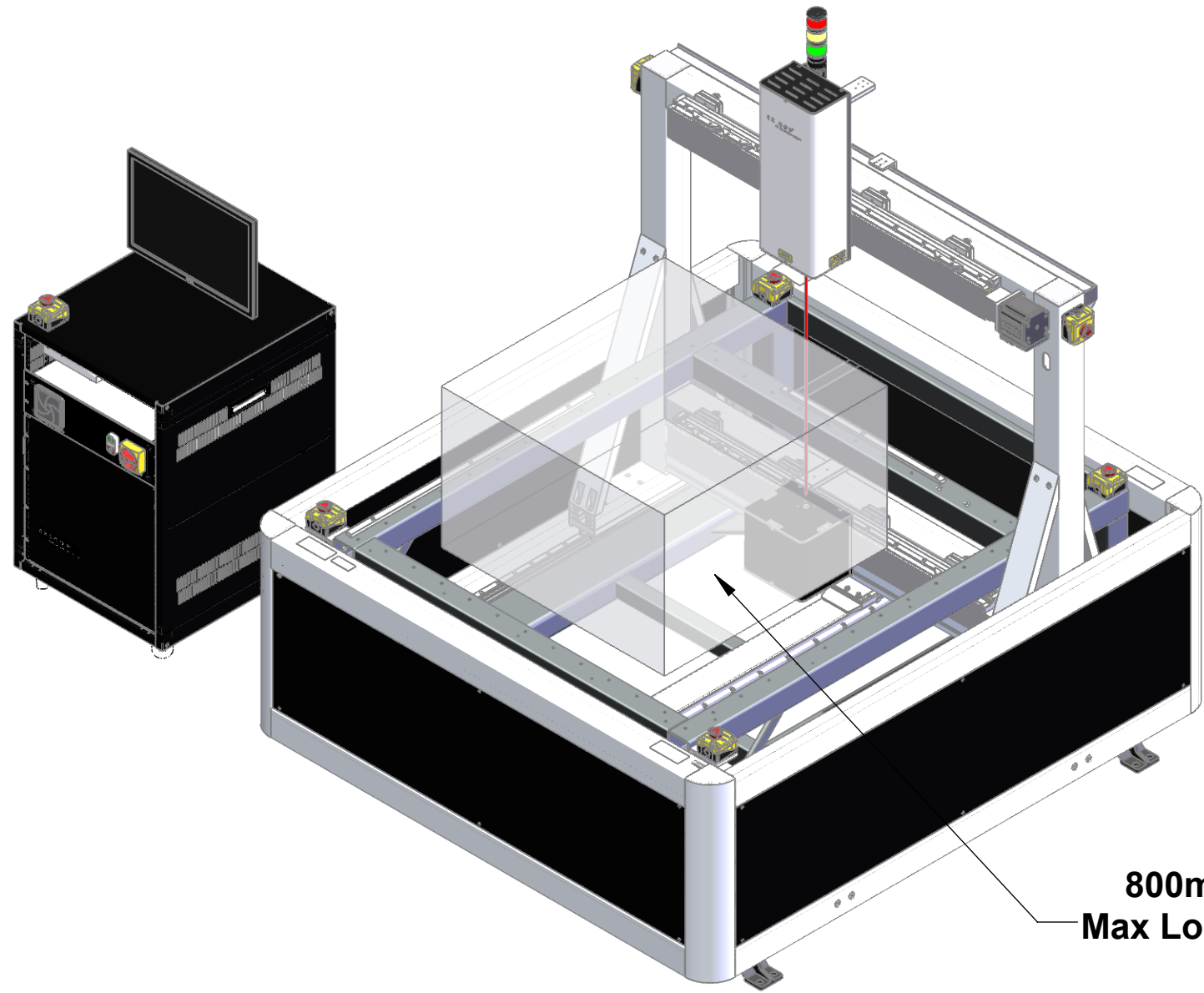

Max Sample Size
800mm x 800mm x 500mm
Max Load with Sample + Holder
1910 lbs / 865 kg

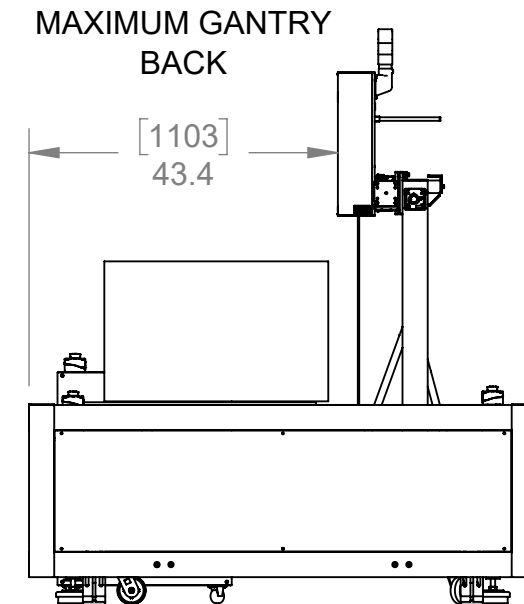
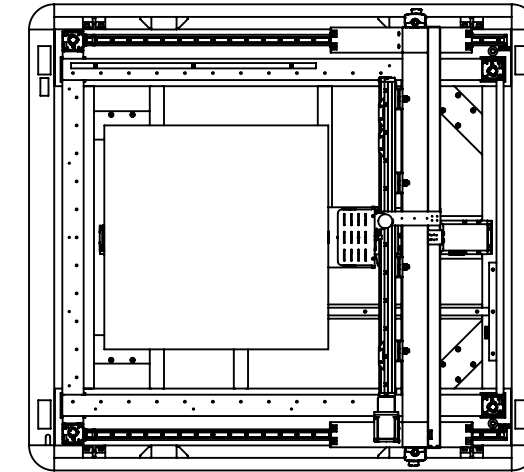
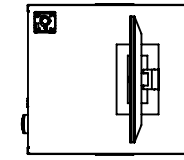

UNSPECIFIED LIMITS DIMENSIONS ARE IN INCHES		DO NOT SCALE DRAWING		 HINDS Instruments, Inc. <small>7245 NE Evergreen Pkwy, Suite 150 Hillsboro, OR 97124 PHONE (503) 690-2000 FAX (503) 690-3000</small>	
FRACTIONS	± 1/32	STRAIGHTNESS &/OR FLATNESS:	.005/INCH	DATE PRINTED:	
DECIMALS	.XX ± .010 .XXX ± .005	THREADS:	EXTERNAL - CLASS 2A INTERNAL - CLASS 2B	APPROVALS	DATE
HOLE DIA's	.XX ± .010 .XXX ± .003 ± 0° 30'	UNMARKED ANGLES, BENDS & INTERSECTIONS:	90°	cmansfield	3/8/23
ANGLES	± 2°	MACHINED SURFACES:	63 OR BETTER	CHECKED	
BENDS	± 2°	REMOVE ALL BURRS & SHARP CORNERS		MATERIAL	
PERPENDICULARITY	.003/INCH			FINISH	
CONCENTRICITY	.003 TIR				
SAMPLES MUST BE APPROVED BY ENGINEERING DEPARTMENT PRIOR TO STARTING PRODUCTION				SIZE	FSCM NO.
THIS DRAWING IS THE PROPERTY OF HINDS INSTRUMENTS INC. ALL RIGHTS RESERVED.				B	
				DWG. NO.	REV.
				010-0000-113-R	0
				SCALE	RELEASE DATE:
				1:27	SHEET 2 OF 2