

E X I C O R[®] MICROIMAGER[™]

BIREFRINGENCE | MEASUREMENT SYSTEM

USER MANUAL



Hinds Instruments, Inc.
P/N: 010-0000-077-01 UM Rev B

Software 025-0000-075 ver 2

Copyright © 2015-2023 by Hinds Instruments, Inc.

THIS DOCUMENT IS PROVIDED “AS IS” WITH NO WARRANTIES WHATSOEVER, INCLUDING ANY WARRANTY OF MERCHANTABILITY, FITNESS FOR ANY PARTICULAR PURPOSE, OR ANY WARRANTY OTHERWISE ARISING OUT OF ANY PROPOSAL, SPECIFICATION OR SAMPLE. All rights reserved. No part of this publication may be reproduced, stored in a retrieval system, or transmitted, in any form by any means, electronic, mechanical, by photocopying, recording, or otherwise, without the prior written permission of Hinds Instruments, Inc.

Information furnished by Hinds Instruments, Inc. is believed to be accurate and reliable; however, no responsibility is assumed by Hinds Instruments, Inc. for its use; nor for any infringements of patents or other rights of third parties which may result from its use. No license is granted by implication or otherwise under any patent rights of Hinds Instruments, Inc.

In all respects, the English version of this manual is controlling.

Exicor® is a registered trademark of Hinds Instruments, Inc.

The Exicor® Microlmager is covered by the following US patent(s): (1) 11,686,957
Additional patents pending.

Exicor®, Signaloc, PEM Labs, Hinds Instruments and the Hinds Instruments graphic logo are trademarks of Hinds Instruments, Inc.

*Third-party brands and names are the property of their respective owners

Table of Contents

Table of Contents	iii
Table of Figures	v
Operator Safety Summary	6
Terms	6
Labels	6
Power Source	6
Do Not Operate without Covers	7
Light Safety	7
Mechanical Safety	8
Electrical Safety	8
1 System Overview.....	9
System Description.....	9
General Dimensions.....	12
2 System Operating Requirements/Setup	13
Component Placement	13
Power Connections.....	13
Calibration	13
3 Operating the System	14
System Initialization.....	14
System Warmup.....	15
Loading a Sample	16
Measuring a Sample.....	17
System Shutdown	18
4 Software Interface	19
Calibration	19
File Management.....	19
Setting Exposure & Live Views	20
Changing Objectives.....	20
Offsets	20
Display of data.....	21
Analysis	22
Multi-Order Samples	24
5 Calibration	26
Calibration Setup	26
Calibration Procedure.....	27
6 Maintenance	32
Basic System Check	32
Cleaning the Exterior	32
7 Troubleshooting & Help.....	33
Diagnosing Common Errors.....	33
Contacting Hinds Instruments	34
A Technical Specifications	35
General Specifications.....	35
Measurement Specifications	35
Software Features	36

B Exicor® Microlmager Limited Warranty..... 37
 Exclusions..... 37
 Warranty Service..... 37
 Non-Warranty Repairs 38

Table of Figures

Figure 1 System identification label	6
Figure 2 Light beam path.....	8
Figure 3 System main components	10
Figure 4 Main optical components of the system	11
Figure 5 Dimensions	12
Figure 6 Main Window	15
Figure 7 Ximea CamTool settings window w/ temperature expanded.....	15
Figure 8 Stage axis controls.....	16
Figure 9 Completed scan.....	18
Figure 10 Offset Tool	21
Figure 11 Data Tab	21
Figure 12 Analysis Toolbar.....	23
Figure 12 Phase Unwrap groupbox.	25
Figure 13 Measuring Left Side of Stage.....	26
Figure 14 Measuring Right Side of Stage.	27
Figure 15 Position of Rotator.	28
Figure 17 Calibration procedure in process.....	29
Figure 9 Completed calibration procedure.....	29
Figure 18 Marking Location.	30
Table 1 Diagnosing common errors.....	33
Table 2 Contacting technical support.....	34

Operator Safety Summary

The general safety information in this summary is for operators of the Exicor® Microlmager. Specific warnings and cautions may be found throughout the manual where they apply but may not appear in this summary.

Terms

DANGER statements identify conditions or practices that will result in personal injury or loss of life.

WARNING statements identify conditions or practices that could result in personal injury or loss of life.

CAUTION statements identify conditions or practices that could result in damage to the equipment or other property.

NOTICE statements identify conditions or practices that are important in proper use of the equipment to get the expected results.

Labels

The system identification label below is placed on the rear of the Microlmager frame.

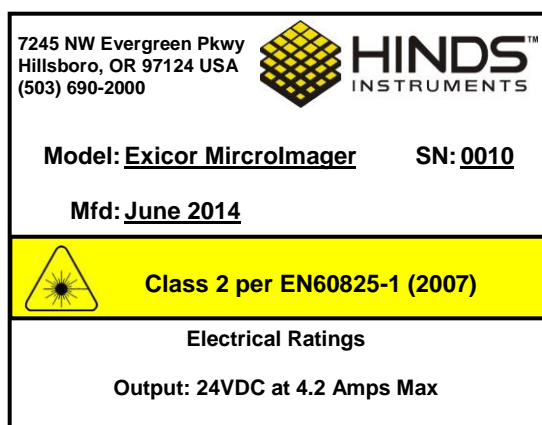

Figure 1 System identification label

The wording on this label is:

Model Name _____, Serial No. _____, Manufacture Date: _____.

Power Source

This product is intended to operate from a power source that will not apply more than 250 volts rms between the supply conductors or between either the supply

conductor and ground. A protective ground connection by way of the grounding connector in the power cord is essential for safe operation. The user should supply power to the system that will provide at least the following amount of current at the corresponding supply voltage:

100-240VAC, 50/60Hz, 1.5A MAX

The Microlmager system uses a single AC power cord to power a DC power brick. If the power cord needs to be replaced for any reason, make sure that the replacement cord is rated for the voltage and current noted above

Do Not Operate without Covers

To avoid personal injury, only operate this product with all covers and panels installed.

Light Safety

The light source is located in the bottom module of the system. It is a 4 wavelength LED that outputs <1mW. Removing any covers can expose a user to the LED light. The light beam path is shown in Figure 2.

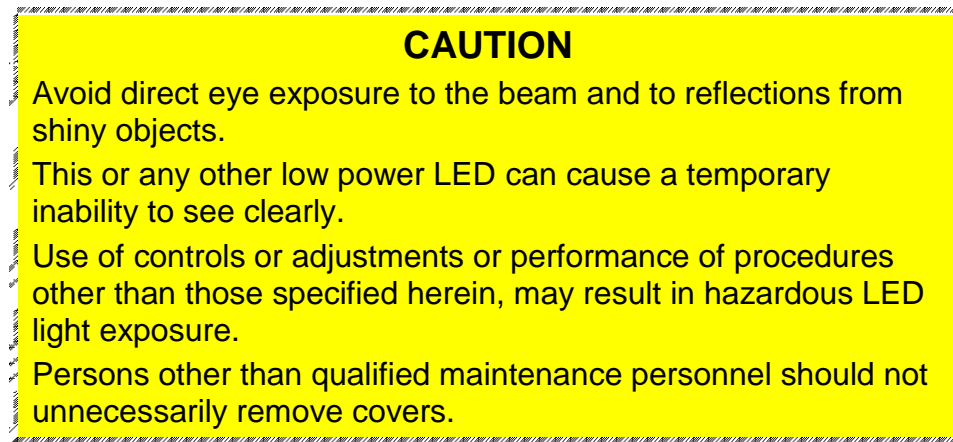

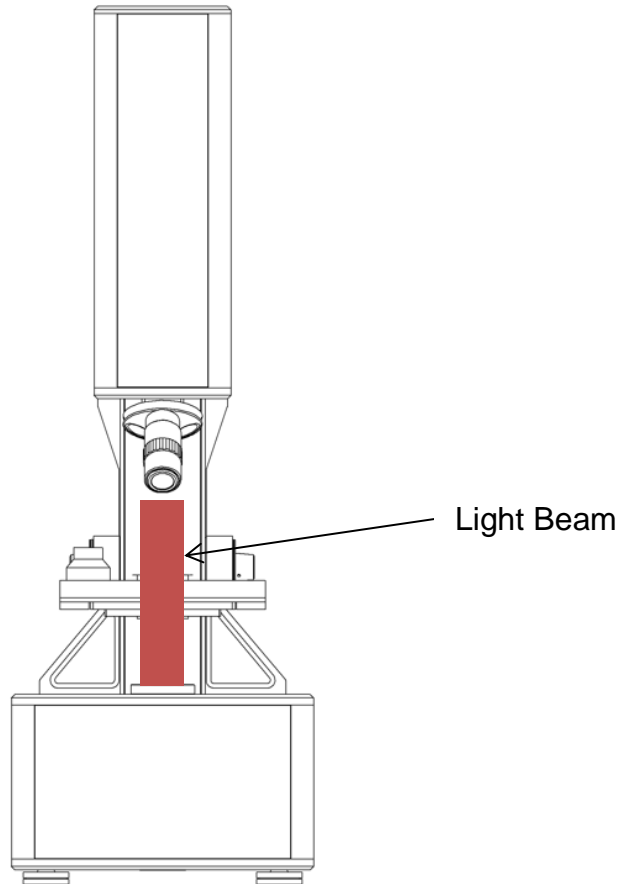

Figure 2 Light beam path

Mechanical Safety

Be careful to have hands clear of any pinch points while operating the focus block and sample stage.

Electrical Safety

Rear panel outlets, other than the DC input are only USB 3.0 connectors which do not exceed 5 Volts.

The Exicor® Microlmager contains no user-serviceable components. Refer any maintenance or adjustment needs to Hinds Instruments, Inc.

Do not allow any liquids to get inside the equipment.

Maintenance of the other elements of the system should be referred to Hinds Instruments, Inc. or other trained personnel (i.e. computer, monitor, etc.)

1

System Overview

The Exicor® Microlmager is a highly sensitive polarization imaging system that utilizes different microscope objectives to image very small features of samples. It measures retardation and fast axis angle. Samples need to be flat/planar and transparent to the wavelength that is being used.

System Description

Listed below are the main components of the system. See Figure 3 for the component layout.

Top Module: The Top Module houses the top half of the optical components (polarization state analyzer) of the imaging system.

Focus Block: The Focus Block has both fine and coarse adjustment knobs. Use the larger outer knob to adjust the coarse focus and the smaller inner knob to adjust the fine focus.

Bottom Module: The Bottom Module houses the electronics of the system as well as the bottom half of the optical train (polarization state generator) for the system. The bottom half also houses the light source.

Sample Stage: The Sample Stage can be moved in the vertical direction by the focus block while having an X travel of 76mm and a Y travel of 50mm.

Microscope Objective: The Microlmager comes with a variety of different options in objectives, most commonly in 2X, 5X, 10X and 20X. The system comes equipped with an objective turret for ease of switching objectives. When changing objectives, the focus block may need to be readjusted to bring the sample back into focus.

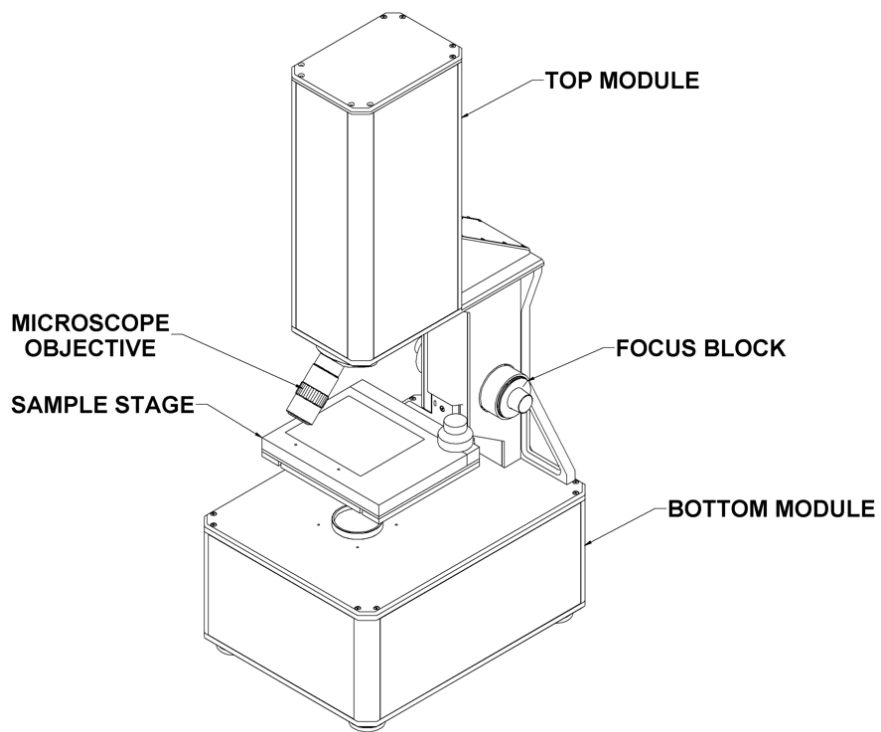

Figure 3 System main components

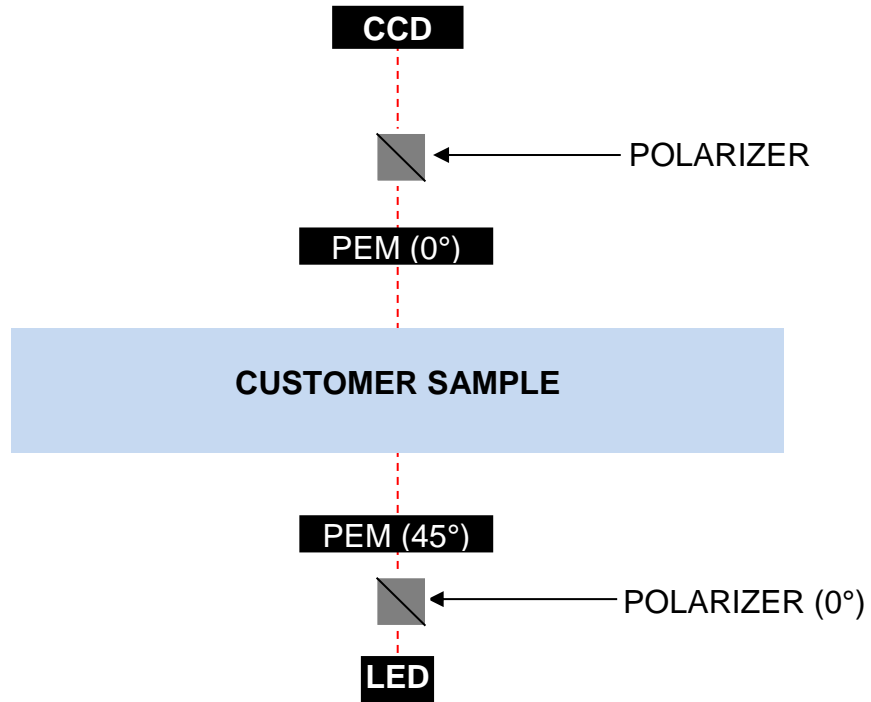

Figure 4 Main optical components of the system

General Dimensions

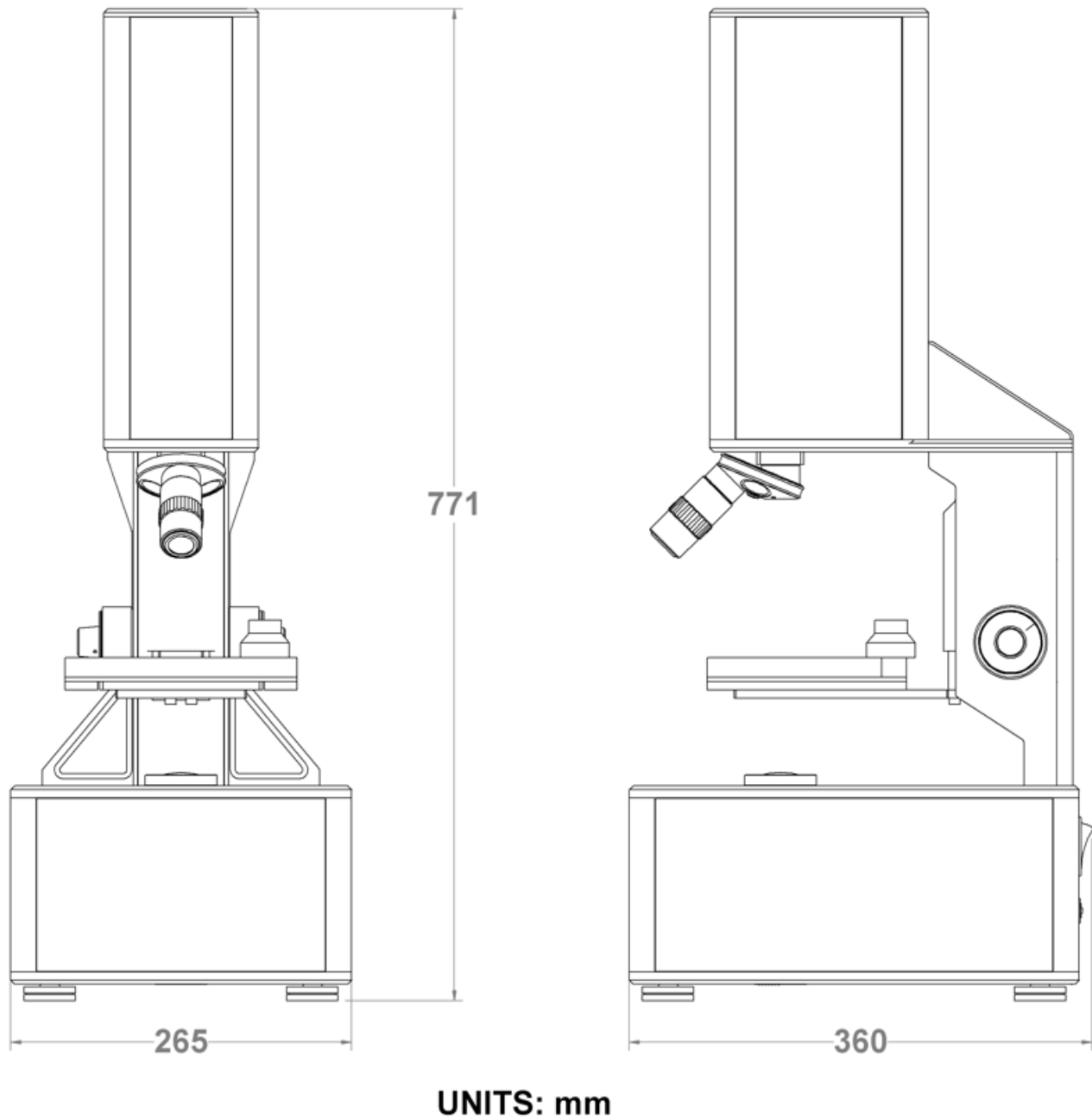

Figure 5 Dimensions

2

System Operating Requirements/Setup

Component Placement

The computer and monitor need to be placed within 0.5 meter of the system to facilitate connection of all hardware control cables.

Power Connections

The Exicor® MicroImager system is designed to use an external DC power supply that outputs 24VDC while accepting 100-240VAC, 50/60 Hz. User adjustment should not be necessary for any internal components due to changes in power.

The Exicor® MicroImager system requires a single power outlet. The computer and monitor need to be powered separately from a user-supplied wall outlet or outlet strip.

Calibration

The Exicor® MicroImager has been calibrated by Hinds Instruments, Inc. prior to shipment. The instrument should require no further adjustment for most applications. Regular use of offsets will ensure the best low level sensitivity for all measurement parameters. Hinds Instruments recommends daily offsets in a moderately temperature stable lab and hourly in an unstable environment.

Note: All systems sold by Hinds Instruments are currently installed and supported only through Hinds Instruments, Inc. and authorized distributors.

3

Operating the System

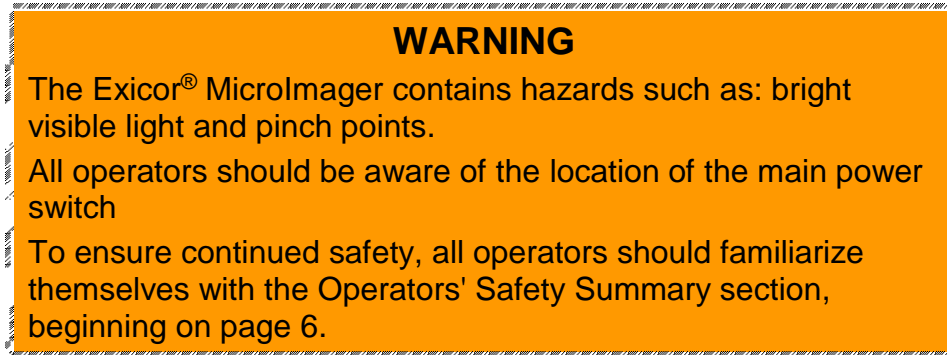

System Initialization

To initialize the Exicor® Microlmager system, starting with the power off:

1. Confirm the power and USB cables are correctly connected to the system. The USB requires a USB 3.0 port on the PC.
2. Turn the power switch to the ON position. The power switch is found on the rear panel of the machine.
3. Launch the software by double clicking on the Microlmager desktop icon.

During hardware initialization, the user might notice the LED and camera will initialize using the settings from the previous use.

If the correct comport is used/referenced and there are no other errors during the initialization phase, the main window will come up as shown in Figure 6.

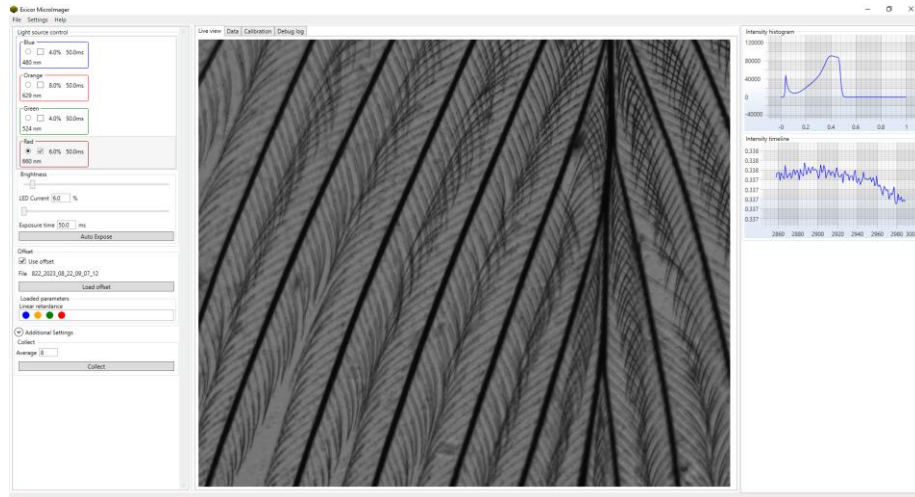

Figure 6 Main Window

If an error is witnessed during the initialization phase, see section 7 “Troubleshooting & Help” on page 33 for system initialization errors.

In the case that the hardware has already been powered up, such as from a computer restart, simply start the software.

System Warmup

For accurate measurements, it is important to let the system warm up. The critical component that needs to warm up is the camera. The camera’s temperature can be monitored by the Ximea CamTool package installed on the system PC. There should be a shortcut on the desktop. The settings window has a “Temperature” drop down that will give real time camera temperature. Camera’s tend to hit stability while in Hinds Instruments’ lab around 51-55°C:

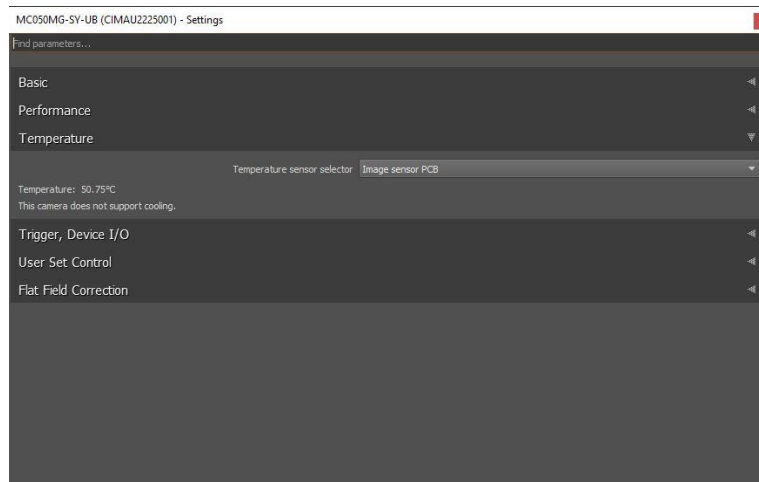

Figure 7 Ximea CamTool settings window w/ temperature expanded

Loading a Sample

This system includes a basic manually operated sample stage. The best way to get reproducible measurements is to make a custom sample holder that fastens to the stage in a repeatable way. Hinds Instruments can also supply custom sample holders as an option.

Use the following steps to load a sample:

1. Place the sample on the stage. Do not hold the sample to the stage in a way that might put stress on the sample.
2. Using the manual adjusters, move the sample to the desired location on the software's live screen. The adjustment knob controls both the X and Y-axis adjustments. The X-axis is controlled by the bottom part of the knob. The Y-axis is controlled by the top part of the knob. See Figure 8.

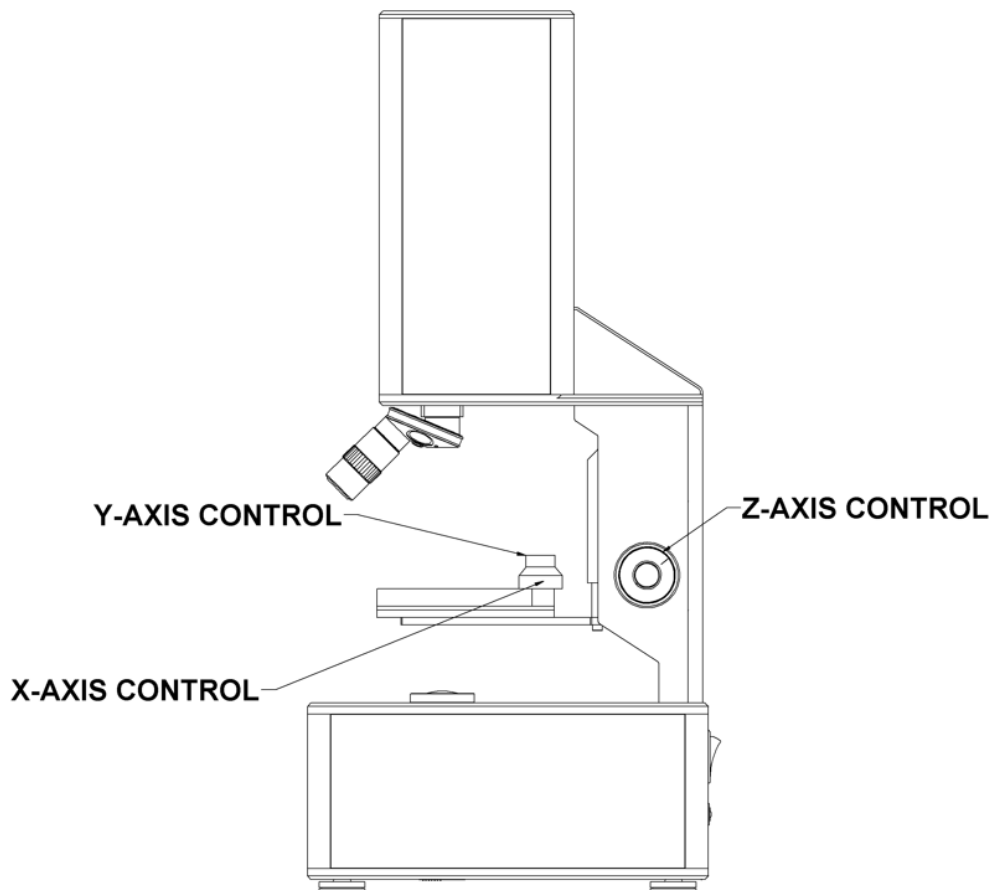

Figure 8 Stage axis controls

Note: It is preferable to wait at least 10 minutes before measuring samples after handling in order for the sample to reach thermal equilibrium. Handling

the sample can change its temperature temporarily, which may also affect the retardation measurement. The wait time may be different for samples of different sizes or different material.

Measuring a Sample

1. Choose the color of light desired by clicking the corresponding checkbox. Multiple colors can be selected.
2. Set the Light Level/Exposure. This can be done using the “Auto Expose” button or by hand.
 - a. By Hand: The LED current slider and user entry box will adjust the current supplied to the LEDs. The exposure slider and user entry box will adjust the exposure time of the camera. The goal is to achieve an intensity peak near 0.5 using the intensity histogram.
 - b. Multiple LEDs can be auto exposed at once if multiple LED check boxes are checked and the “All” checkbox next to the “Auto Expose” button is checked.
3. If an offset is desired, load an air offset hmi file using the “Load offset” button. Make sure the “Use offset” box is checked. It is recommended to take an air offset at minimum daily. If the system is in an unstable temperature environment, hourly offsets are suggested.
 - a. To take an offset, remove all samples from the beam path and follow these “Measuring a Sample” steps. Ensure that the “Use offset” is not checked in case an old offset has been loaded.
4. Set the number of averages at each harmonic to make the measurement. It is recommended to use 4-16 averages for the best results in a timely manner.
 - a. ****This is the preferred way to capture offset files.**
5. Press the “Collect” button.
6. **Additional Settings:** Expand the additional settings to use the following functions:
 - a. Select the optical parameters to measure. ****Early systems will only allow linear retardation measurements.**
 - b. If you would like the software to automatically save the data to a local location, check the “Enable HMI Autosave” box, name the file and select if a timestamp is desired and use the directory explorer from the “Set” button to select where the file is saved.

Once the scan starts, there is a status bar at the bottom showing the amount of progress of the scan.

When the scan is complete, the software will switch to the Data tab and display the results as shown in Figure 9.

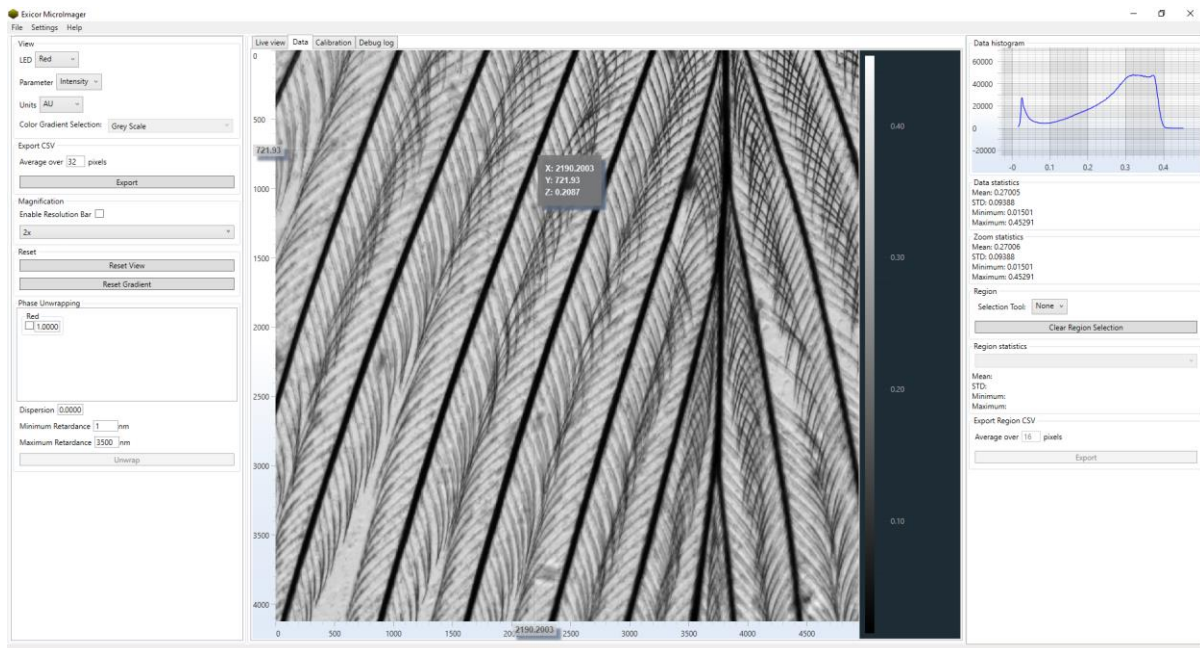

Figure 9 Completed scan

If the data needs to be saved and auto save was disabled, simply select **File→Save** and select which data format to save or quickly save a comma separated value (.csv) using the “Export” button in the data tab’s left panel.

System Shutdown

1. Close the Microlmager software using the close button in the top right corner or navigate to **File→Quit**.

Move the start/stop switch to the OFF position. All hardware devices inside the system will shut down. The PC and monitor can be shut down independently if necessary.

4

Software Interface

Depending on the options purchased with the MicroImager, different software options may be available. This chapter explains the rest of the software interface in detail, including:

- Calibration
- Opening Files
- Setting Exposure
- Changing Objectives
- Offsets
- Display of Data
- Evaluation of Data
- Analysis
- Multi-Order Samples

Calibration

The system does not need to be recalibrated on a regular basis but it is up to the user to decide if they want to recalibrate the system. Reasons Hinds Instruments would recommend recalibration include the following:

1. Moving the system from to a different room with drastically different temperatures.
2. There has been a substantial effect of some kind upon the instrument to doubt the calibration.
3. The system is not measuring reference samples correctly.

For more information on how to calibrate the instrument see Section 5 Calibration.

File Management

Saving: To save a file in the format that the Microimager can reload go to File→Save or use the “Enable HMI Autosave” checkbox in the left panel of the “Live view” tab.

Export: To export the data in a .hmi, .csv or the heat map in a .png file, go to File→Export. A .csv file can also be exported from the “Data” tab. This location also allows the user to set how many pixels to average over for smaller files.

If the .png tool is used, the .png will be of the region of the heat map currently in view.

Opening: To open a file, go to File→Load, and select the corresponding .hmi file.

Setting Exposure & Live Views

During the calibration, the software determines the optimal setting for the exposure and brightness for a blank sample. Pressing the “Auto Expose” button runs the same routine to find the optimal settings.

If the sample has low transmission, it is possible to use the LED current and camera exposure slider bars to increase the amount of light entering the camera. Left is minimum and right is maximum for both bars. You can move the sliders to the right until the optimal brightness is achieved. Optimal brightness is when the intensity histogram peaks near 0.5.

The live view can switch between a standard view and polarized view. The polarized view gives some contrast to view high retardance areas in real time. This aids in focusing on areas of interest without waiting for a scan.

Changing Objectives

To change objectives, rotate the objective turret to the target objective. Ensure you hear the turret click into place. Click the Auto Expose button to readjust the light intensity for that objective or adjust the LED current and exposure time slide bars appropriately for each LED being used.

Offsets

The offset button is found above the collect button in its own designated box.

Clicking this button will open a file explorer that should be used to select an .hmi file of a measurement of air with no sample in the path, using the intended objective. The retardation and angle of every pixel will then be stored in memory from this file to be subtracted after a new measurement.

After you take an offset, you can choose to use the offset or not by checking the box above the offset button.

A loaded offset will display which optical parameters and color combinations have a value that will be applied. For example, a blue/red, linear retardance offset will display as:

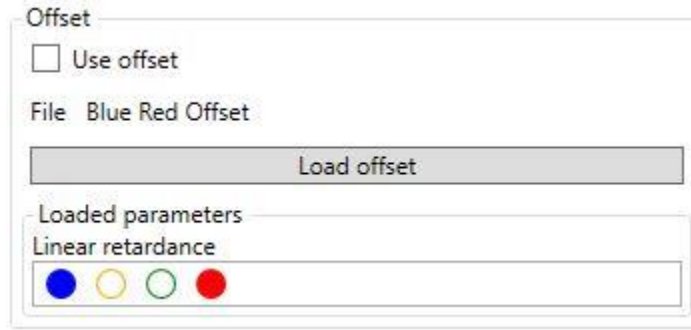

Figure 10 Offset Tool

Each objective will have its own unique offset. For example, an offset taken with the 2X objective should not be used with any objective other than the 2X.

A daily offset is recommended for systems used in a stable temperature environment. More frequent offsetting is recommended in less stable environments.

Display of data

The data tab contains a heat map of the measured data, a histogram of the current view of data, overall statistics (mean, standard deviation, minimum and maximum) and the same statistics of the current zoomed region.

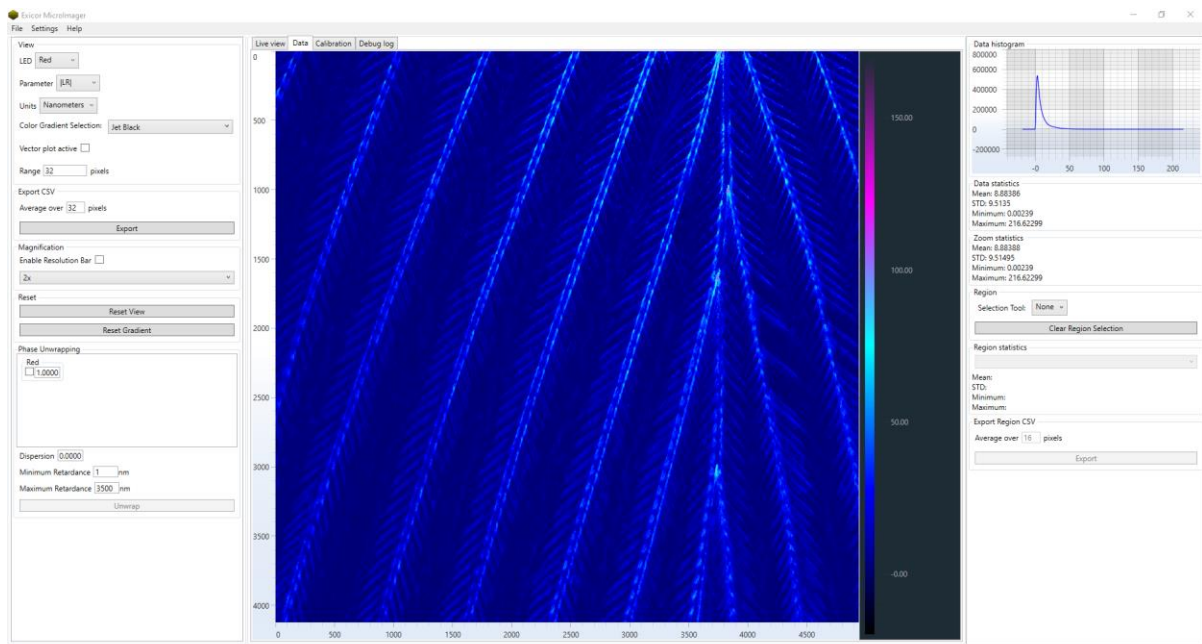

Figure 11 Data Tab

Optical Parameters: Data is displayed in 5 Different formats. Intensity, Retardance Magnitude ($|LR|$), Retardance Angle (LR Angle) and the raw X and Y component data. The XY data are the raw values used with the intensity data to calculate the magnitude and angle. Each parameter has its own set of units to choose for viewing.

Hovering the mouse over the heat map data will display point data of the image pixel captured with the mouse. The tool tip will display the coordinate x and y location along with the selected optical parameter as the z value.

The retardance angle data can be displayed as a vector field at any time by checking the “Vector plot active” checkbox. The length of the vector can be adjusted using the “Range _ pixels” box.

Image Resolution: A scale bar can be enabled at any time using the “Enable resolution bar” check box in the “Magnification” group. Selecting the objective used will scale the heat map data to keep the scale bar appropriate. Based on the objective and zoom, the scale bar will adjust and display the resolution in microns.

Color: When displaying single sets of data the gradient scale to the right of the heat map provides the legend to the data. The minimum and maximum values can be clicked and dragged to adjust up or down. The “Reset Gradient” button in the left panel will reset the value to the original values.

To change the color gradient, use the “Color Gradient” dropdown of presets. There are nine (9) available options, including options optimized for users with difficulty perceiving colors or contrast.

Navigation:

A user can left click and drag the heat map to pan in any direction.

The mouse wheel can be used to zoom in and out of the heat map.

An area can be zoomed in on when captured with a right click and drag.

Double left click of the mouse will reset the heat map or the “Reset View” button in the left panel.

Analysis

The data analysis tools are on the right side panel as shown in Figure 13.

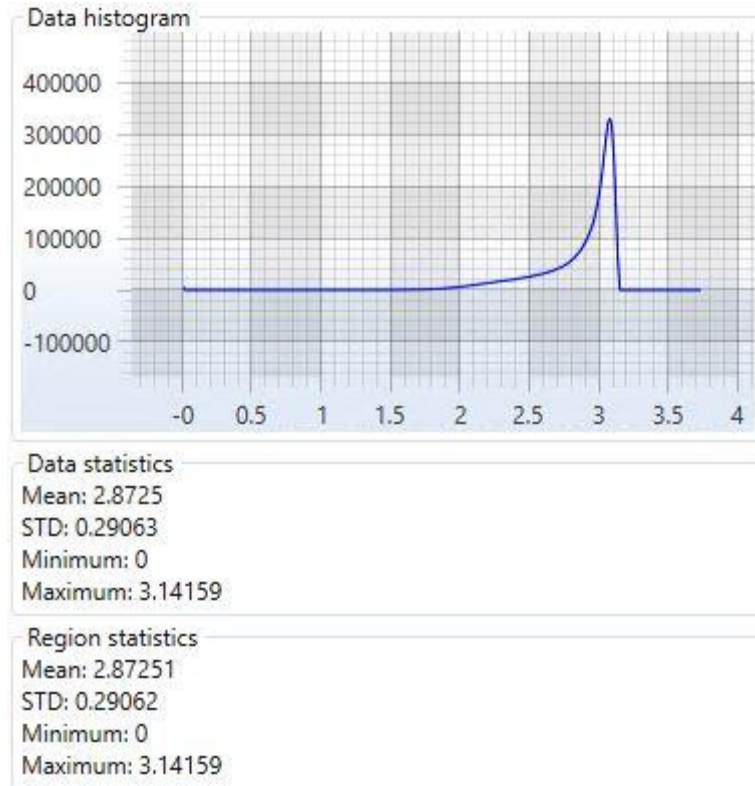

Figure 12 Analysis Toolbar

Histogram: The top of the analysis tool contains a histogram of the data that is currently held in the heat map, meaning if you zoom, the histogram will display only the data of the region of the sample that is zoomed on. The x axis is the unit of measurement selected by the “Units” dropdown box and the y axis is the number of pixels at that value (count). The histogram will update with any zoom or pan of the heat map. Hovering over the histogram will display the pixel count (y value) at that location. All navigation tools of the heat map apply to the histogram as well:

- Pan with left click and drag.
- Zoom with mouse wheel or right click and drag.
- Reset view with double left click or “Reset View” button.

Statistics: Below the histogram are two sets of statistical data: the overall “Data statistics” of the entire sample and the “Region statistics” of any feature zoomed in on. The statistics include the mean value of the area, the standard deviation of data in that area, as well as the minimum and maximum value in the area. The region statistics will update with any zoom or pan of the heat map.

Region Tools: Several region tools are available for highlighting areas of interest from the data. Each shape, with exception of a single line, will report area statistics and statistics of pixels captured by the perimeter. The line shape will only report statistics from any pixel captured by the line. Clear all regions from the data map using the “Clear Region Selection” button.

The available regions are:

- **Line**- simple two point line. Start and finished with one left click each.
- **Polyline**- functions similarly as line, but with multiple vertices. Finished when left click is near the starting vertex.
- **Rectangle**- simple rectangle. Start and finished with one left click each.
- **Ellipse**- all manner of round shapes. Start and finished with one left click each. First click will set the center, the next click will set the radius. Zoom will affect area becoming elliptical.
- **Polygon**- multiple lines but will enclose an area. Start with one left click and add vertices with single left clicks. Finished with one left click near the starting vertex.

Statistics will automatically populate after a region is selected. The dropdown menu in “Region statistics” will allow a user to switch between area and perimeter statistics if applicable.

Comma separated value file (.csv) of the region can be created by using the “Export” button in the “Export Region CSV” group.

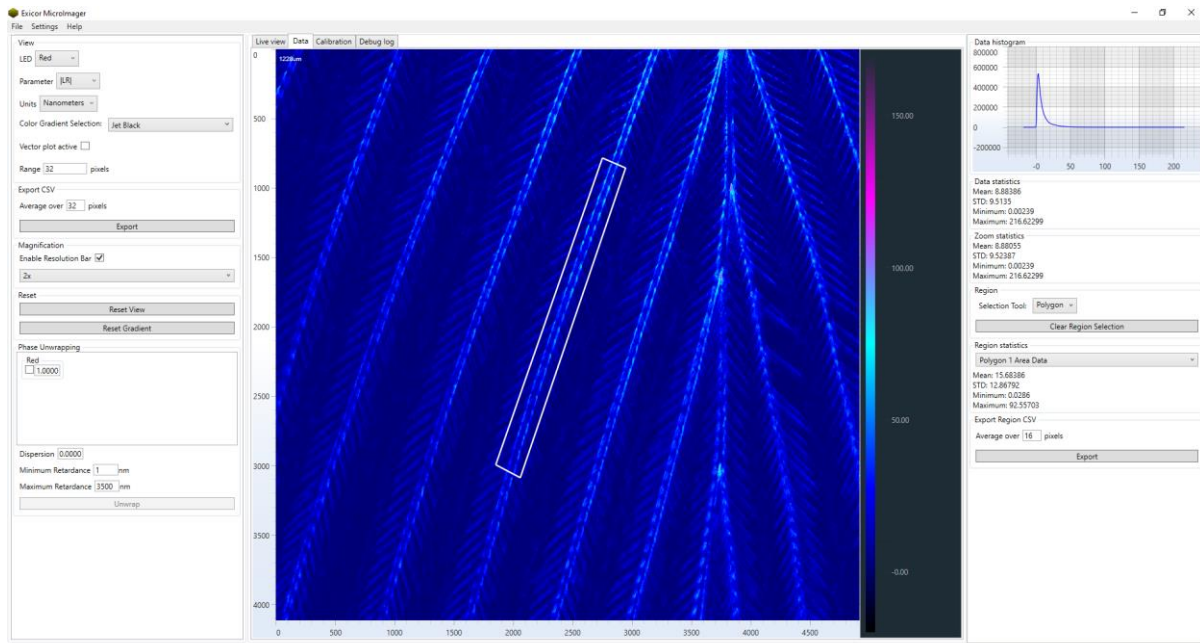

Multi-Order Samples

Occasionally, there is a need to measure retardation beyond the limit of a single wavelength. To do this multiple wavelengths need to be measured and unwrapped to find the correct order and value of a sample.

To complete this:

1. Measure your sample with multiple wavelengths. To do this, check the checkbox of the wavelength in the “Light source control” box of the main interface.
2. After a multiple wavelength scan is complete, the “Phase Unwrapping” box of the Data tab will enable itself. From here, the user can select which wavelengths to use to unwrap the data by checking the checkbox next to the color name. A user can adjust the scaling factor of the LED wavelength using the text box. LED sources inherently have a wide bandwidth that may drift with temperature changes. This tool allows for flexibility in the wavelength used in the phase unwrapping algorithm.

Phase Unwrapping

Blue
 1.0000

Orange
 1.0000

Green
 1.0000

Red
 1.0000

Dispersion 0.0000

Minimum Retardance 1 nm

Maximum Retardance 3500 nm

Unwrap

Figure 12 Phase Unwrap groupbox.

3. After selecting which colors to use in the unwrapping, adjust the minimum and maximum expected retardation values as well as the dispersion of the material, if known, and click “Unwrap”. The software will not allow a maximum input larger than the system is capable of measuring.

It will take some time but the software will process the images and give you a multi-order result.

5

Calibration

Calibration Setup

Before beginning the calibration procedure, a few tools will need to be acquired. The calibration process requires a high quality achromatic quarter wave plate with known axis of polarization. A precision rotation stage is also required. Some sort of temporary adhesive (i.e. sticky tack) is helpful, but not necessary.

The calibration software can be accessed on the “Calibration” tab of the main interface.

Before beginning, make sure the system is properly warmed up and in a thermal environment that is comparable to the normal conditions the system will be used in.

Additionally, ensure that the stage is level. Measure each edge of the stage as shown in Figures 13 and 14. The stage will move slightly with light to moderate pressure. If it isn't possible to make the stage level, remove the panel behind the stage with a M3 hex wrench, then loosen the stage, level it, and retighten the screws. Check to make sure the stage is level again after retightening the screws.

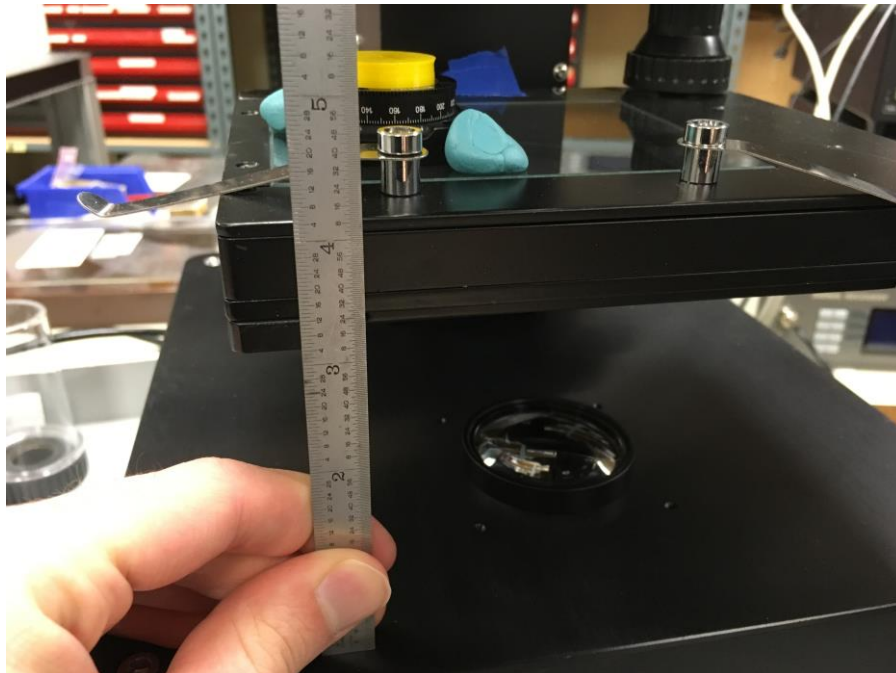

Figure 13 Measuring Left Side of Stage.

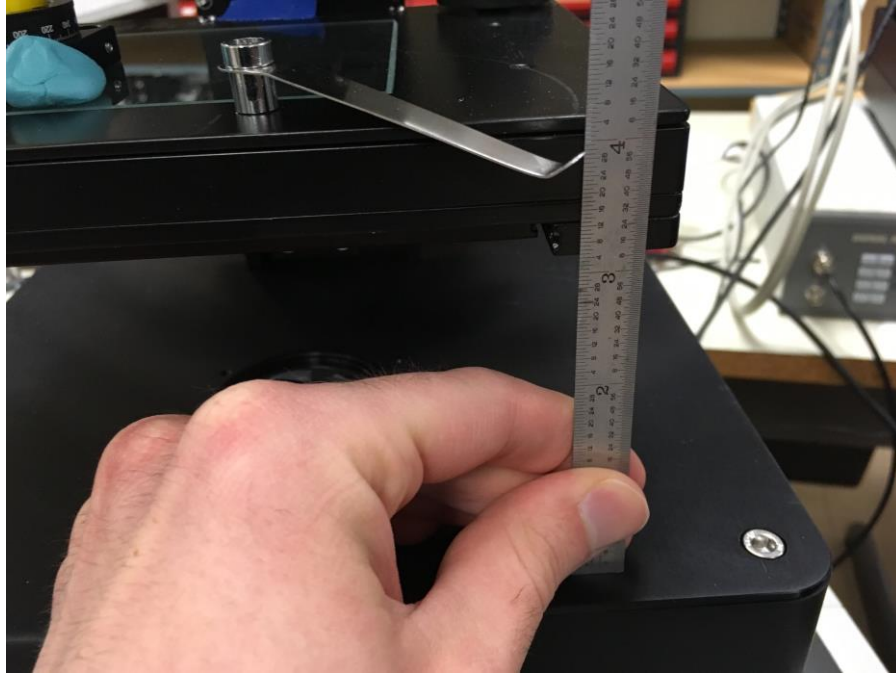

Figure 14 Measuring Right Side of Stage.

Calibration Procedure

1. With the calibration tab open, start with the Exposure calibration and work down the list of harmonic and amplitude calibrations. To begin a calibration, select the procedure and press “Collect”. Procedures will display whether they are complete or incomplete. After pressing collect, the software will designate which optic and at what orientation to place the optic for the procedure. Some call for air. In this case, make sure there is nothing in the beam path but clean glass from the stage. If an optic is required, ensure the optic is centered. To do so, select “Cancel”, switch to the “Live view” tab, run through the following procedure and go back to the “Calibration” tab to run the procedure.
2. **Centering an optic:** Place the rotation stage with the Hinds supplied alignment pinhole onto the stage and fix it with blue sticky tack. It should look like Figure 15. Generally, it's best to have the mark facing forward for ease of reading the measurement.

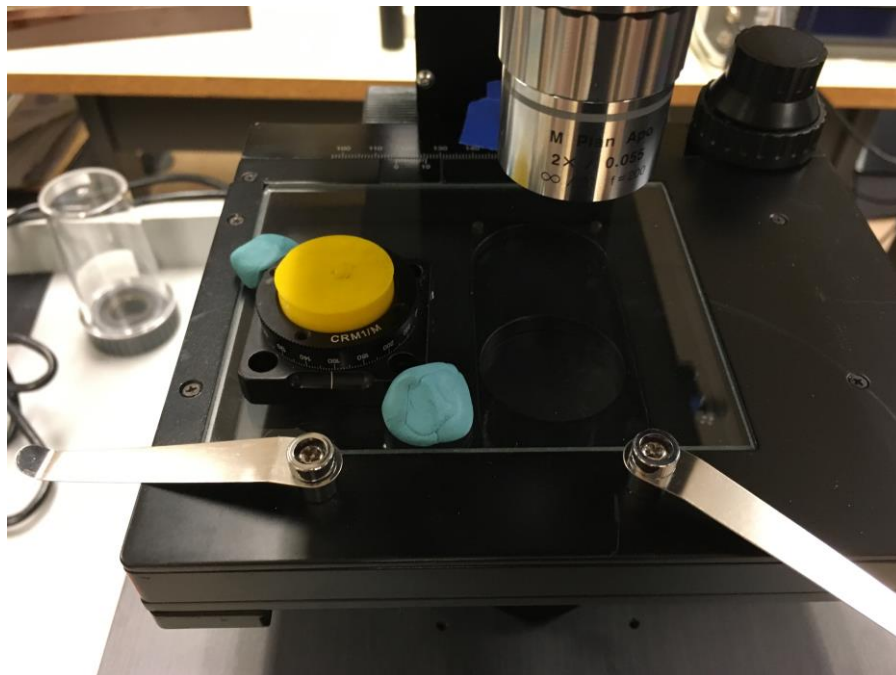

Figure 15 Position of Rotator.

3. Switch to the “Live view” tab in the software and move the sample stage until the rotation stage with the pinhole is centered in the middle of the display. It should look like Figure 16. You may need to increase the intensity of the light by adjusting the LED current slide bar.
4. **Remove the pinhole alignment tool.** Return to the calibration tab and run the next calibration step.



Figure 16 Centering Pinhole.

5. As the calibration procedure runs, it will plot data points in the current LED color. When complete with a color, a line fit of the data points will appear.

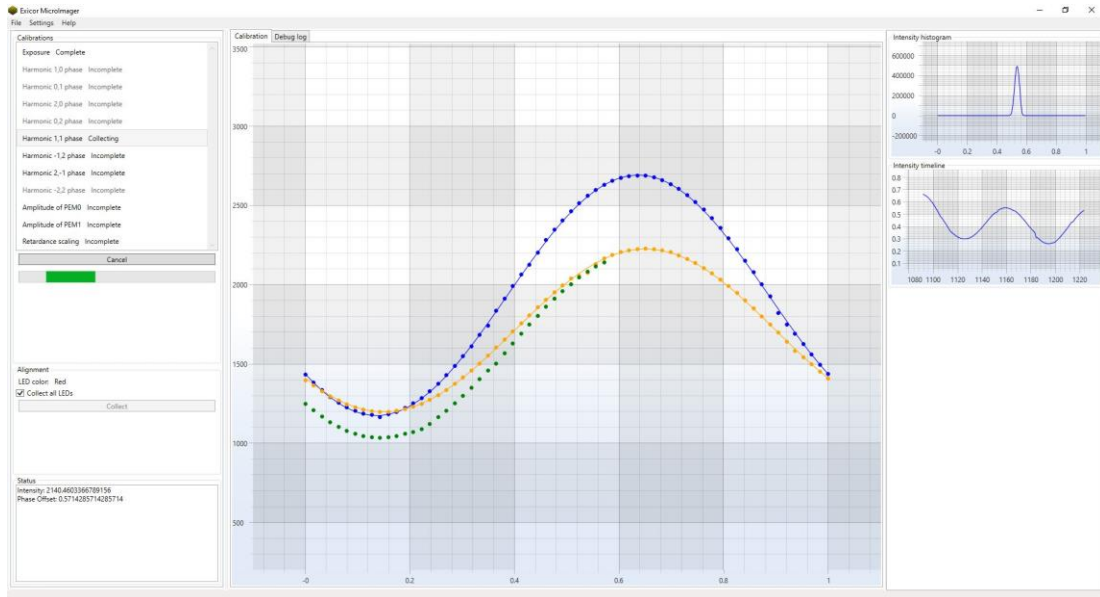

Figure 17 Calibration procedure in process

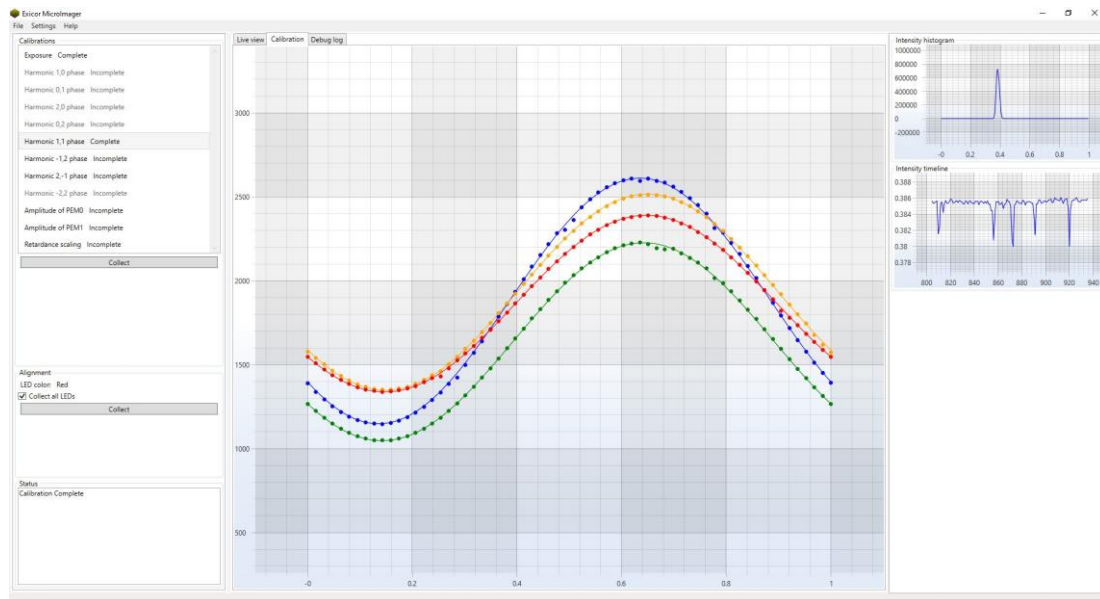

Figure 9 Completed calibration procedure

6. **Retardance Scaling:** Before beginning the retardance scaling procedure, center an achromatic quarter wave plate in a precision rotator using the centering procedure above. Note: It is helpful to orient the rotator so that you can see the angle indicator. This procedure requires precise rotation of the optic by the user. After aligning the waveplate, **remove the pinhole alignment tool.**
7. Mark the x direction of the sample stage with either a piece of tape as shown in Figure 18 or note the value on the ruler. It doesn't matter what is chosen, so long as the stage can be put back in the same position.

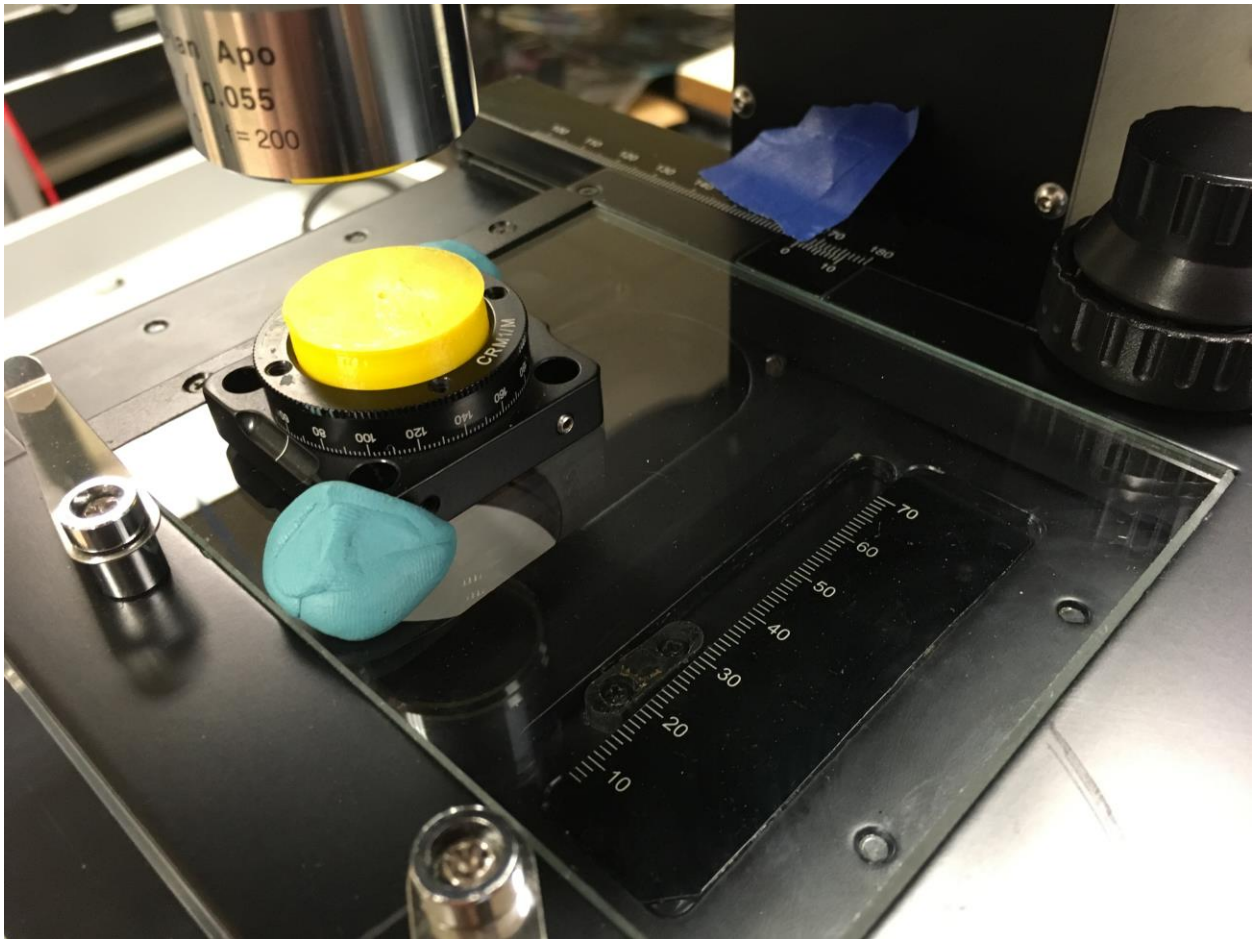

Figure 18 Marking Location.

8. After marking the center on the x-axis, move the rotation stage out of the way by only turning the x-axis adjustment.
9. Start the retardance scaling procedure. After the first data set (air) is complete, a pop up will prompt you to move the wave plate back into the beam path. The first measurement should be taken with the rotator marked at

- 0 degrees, though it doesn't matter if the waveplate's optical axis is in line with the rotator.
10. The software requires the calibration sample to be measured at eight different orientations. These should be measured with the precision rotator marking 0, 22.5, 45, 67.5, 90, 112.5, 135, 157.5 and 180 degrees.
 11. After completing all calibration parameters, the system is ready to use.
****NOTE:** The new calibration parameters will save to the system's configuration files on the PC. To ensure proper storage, use the close window button or File→Quit to exit the software. Any other method or powering down the PC without exiting the software could result in loss of the data.

6

Maintenance

The Exicor® Microlmager requires very little maintenance.

Basic System Check

Check periodically, and when system maintenance is performed, that the covers on the source and detector modules and the control system are secured properly. Be certain that no unwanted light escapes from the source module.

Check periodically that interconnecting cables are free of sharp bends and cuts or abrasions.

For safety, the instrument housings should be opened only by authorized maintenance personnel.

Persons changing the cables or opening the covers on the system must:

- Remove power to the system.
- Understand the purpose, connections and voltages at each cable connection.
- Understand the hazards associated with bright LED light.
- Not allow eye exposure directly from LED light or any reflection of LED light from a mirror like surface.
- Understand all mechanical and electrical hazards that exist in the system.

Cleaning the Exterior

When cleaning the exterior of the Exicor Microlmager, care should be taken not to scratch the surface or let liquids get inside the system.

An ammonia-based cleaner (such as glass cleaner) works well for cleaning the outside. Do not allow any liquids to get inside the sample stage components or top and bottom modules.

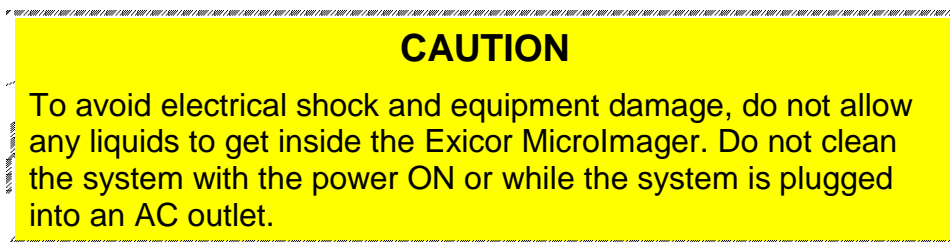

Troubleshooting & Help

Diagnosing Common Errors

Table 1 Diagnosing common errors lists some of the most common errors that have been encountered and suggestions on how to interpret or fix the error.

	Symptom	Common Causes	Actions
1.	Start/Stop switch will not turn system on	DC power cord not plugged in	Plug in DC power cord
2.	The software can't connect to the camera	USB 3.0 cable not plugged in. USB is plugged into USB 2.0 PC port. The computer went into sleep mode. The settings file COMPort is not the system COMPort.	Plug in the USB 3.0 cable. Make sure cable is plugged into USB 3.0 port of the PC. Unplug and then plug back in the USB 3.0 to turn the camera off and then back on again. Check settings file.
3.	Measurements are not close to expected values	The camera is being over exposed.	Use the auto expose button or turn the exposure down manually.
4.	The software freezes	An error within the software	Unplug the USB cable from the computer and turn off the system. Then plug the cables back in and turn the system back on. Be sure to plug USB cables back into the same port on the PC. Restart the software.

Table 1 Diagnosing common errors

Contacting Hinds Instruments

If it is necessary to contact Hinds Instruments for support, refer to the following table for the company contact information.

Method	Information
Telephone	Monday - Friday 8:00 AM to 4:00 PM PST (503) 690-2000
FAX	(503) 690-3000
Email	sales@hindsinstruments.com
World Wide Web	www.hindsinstruments.com
Shipping Address	Hinds Instruments, Inc. 7245 NE Evergreen Pkwy. Hillsboro, Oregon 97124

Table 2 Contacting technical support

When contacting Hinds Instruments for technical support, have the following system information available:

- Model name
- Serial number
- Problem symptom
- Microlmager data files, configuration files, and offsets files (if applicable)

Technical Specifications

The Exicor Microlmager is an easy-to-use system for imaging the birefringence in optical materials. The system includes a sample stage to move the sample for measuring areas up to 76 x 50 mm and function with 2X, 5X, 10X and 20X objectives.

General Specifications

Software:	Exicor™ Microlmager (025-0000-075) Ver. 2.0
Computer System:	PC, Windows™ operating system, LCD monitor
System footprint area:	265 mm x 361 mm (10.4" x 14.2")
System height:	771 mm (30.4")
Stage Travel:	76mm x 50mm
Weight:	15.79 kg (34.74 lbs)
Power Required:	100-240VAC, 1.5A MAX, 50/60Hz

Measurement Specifications

LED Colors:	Blue, Green, Orange, Red *
-------------	----------------------------

* system specific wavelengths displayed in software

Field of View:

2X	4.941 mm x 4.123 mm
5X	1.83 mm x 1.53 mm
10X	0.876 mm x 0.731 mm
20x	0.437 mm x 0.364 mm

Microns/Pixel:

2X	2.00 microns
5X	0.74 microns
10X	0.36 microns
20x	0.18 microns

Fast Axis Angle

Units:	degrees (°)
Range:	-90° → +90°
Resolution:	0.5 Degrees

Software Features

A system-specific software program provides the following:

- Graphical user interface
- Multiple wavelength Measurement
- Multi-order retardation measurement
- Auto-exposure
- Color plot of all measurements
- Automated data collection and analysis of samples
- On-screen graphing of sample data
- Automatic calibration check, system initialization, and system status monitoring

B

Exicor[®] Microlmager Limited Warranty

Hinds Instruments, Inc. warrants the Exicor[®] Microlmager to be free from defects in materials and/or workmanship for (1) year from the date of delivery, subject to the provisions contained herein. Hinds' warranty shall extend to the original purchaser only and shall be limited to factory repair or replacement of defective parts.

Exclusions

This warranty does not cover consumable parts, normal maintenance or damage resulting from improper use or repair, or abuse by the user. This warranty extends only to repair or replacement, and shall in no event extend to consequential damages. In the event of user repair or replacement, this warranty shall cover neither the advisability of the repair undertaken, nor the sufficiency of the repair itself.

THIS DOCUMENT REFLECTS THE ENTIRE AND EXCLUSIVE UNDERSTANDING OF THE PARTIES, EXCEPT AS OTHERWISE PROVIDED HEREIN. HINDS EXPRESSLY DISCLAIMS ALL OTHER WARRANTIES, EXPRESS OR IMPLIED, PARTICULARLY THE WARRANTIES OF MERCHANTABILITY AND/OR FITNESS FOR A PARTICULAR PURPOSE FOR THE PRODUCTS, SOFTWARE, OR SERVICES CONVEYED. THE OBLIGATIONS SET FORTH IN THIS SECTION SHALL BE HINDS' SOLE LIABILITY AND BUYERS' SOLE REMEDY, FOR BREACH OF THE FOREGOING WARRANT. REPRESENTATIONS AND WARRANTIES MADE BY ANY OTHER PERSON, INCLUDING DISTRIBUTORS, DEALERS AND OTHER INDEPENDENT REPRESENTATIVES OF HINDS WHICH ARE INCONSISTENT OR IN CONFLICT WITH THE TERMS OF THIS WARRANTY SHALL NOT BE BINDING ON HINDS UNLESS REDUCED TO WRITING AND APPROVED BY AN EXPRESSLY AUTHORIZED OFFICER OF HINDS.

This warranty gives you specific legal rights, and you may also have other rights that vary from state to state.

Warranty Service

If you find any defects in material or workmanship or any failure to meet the specifications, you must notify Hinds within the warranty period and obtain a Return

Material Authorization Number (RMA#). This can be done by calling Hinds Instruments at 1-800-688-4463, or by emailing our service department. Return the product to us in proper packaging, freight and insurance prepaid, and clearly marked with the RMA#, and we will either repair or replace it, at our option.

Non-Warranty Repairs

If a product that is not covered by the above warranty needs repairing, we will first provide an estimate of repair charges and then repair the product upon receiving authorization from you. Repairs are warranted for ninety (90) days from the date of delivery.

Reference chapter 7 (Troubleshooting & Help) on page 33 for contacting technical support.



HINDS INSTRUMENTS, INC
7245 NE EVERGREEN PKWY
HILLSBORO, OR 97124 USA
PHONE: 1.503.690.2000
FAX: 1.503.690.3000
EMAIL: sales@hindsinstruments.com
www.hindsinstruments.com

COPYRIGHT © 2006, 2023
HINDS INSTRUMENTS, INC All Rights Reserved
MANUFACTURED IN USA UNDER PATENTS & PATENTS
PENDING
PRINTED IN USA